

NUMERICAL STUDY OF LIGHTWEIGHT CONCRETE BEAMS REINFORCED BY FIBERS AND SUBJECTED TO TORSION

Ahmed H. Emam^{1,*}, Maher Adam¹, Ali S. Shanour¹

¹ Civil engineering department, Faculty of Engineering at Shoubra, Benha University.

*Corresponding author

E-mail address: ahmedhessain6633@gmail.com, maher.adam@feng.bu.edu.eg, ali.shnor@feng.bu.edu.eg

Abstract: The evaluation of torsion investigations is based on the increasing demand for the creative design of curved structural members; yet, they are limited concerning lightweight concrete beams. Lightweight concrete has many and diverse utilizations, including multistory building frames and floors, curtain walls and bridges. This paper investigated the effect of fiber on torsional behavior of lightweight concrete beam. Many variables were studied such as compressive strength of lightweight concrete, fiber type, fiber volume ratio, spacing between stirrups, diameter of stirrups and CFRP reinforcement. The numerical results showed that the increment in fiber content resulted in better mechanical properties and torsional resistance of lightweight concrete beams. The effect of carbon fiber and steel fiber is evident from the volume ratio 2%, which produced the highest ultimate torque enhancement to 77.64% and 76 % respectively. In addition, a rational approach is proposed to predict ultimate torque to develop the torsion design of lightweight concrete beams.

Keywords: lightweight concrete, torsion, finite element, concrete beams.

1. Introduction

The advantages of using lightweight concrete in structures granted to accelerated growth in developed countries. Lightweight concrete is widely used because of its low cost in terms of transportation, reduction in manpower huge reduction of overall weight results in saving structural frames, footing or piles and having better nailing and sawing properties than heavier and stronger normal concrete. Crushed attapulgite rocks [1] are an aggregate, which fired at temperature of 700°C and used as partially or completely replacement with ordinary aggregates to production lightweight concrete. The oven dry density of attapulgite lightweight concrete is 1745 Kg/m³ and achieves a cube compressive strength 28 Mpa Crushed clay bricks aggregate can be utilized in production of lightweight concrete with 1861 Kg/m³ oven dry density and 37 Mpa cube compressive strength [2]. Other studies provide lightweight concrete with compressive strength 19 MPa [3] and 35 MPa [4] Practically. The common tendency of construction has concentrated on the concepts of being more economical and space using efficiently, as well as the aesthetic architectural design in which the structural members are designed to be irregular or curved in shape. Under these conditions, the curved members will be eccentrically loaded and, hence torsion will be induced in the members. Noshay [5], tested six reinforced lightweight concrete beams and subjected to torsion in the experimental program. It is concluded that: the failure mode of light-weight concrete is matching the normal weight concrete when subjected to torsion, The torque at first crack at the beam is proportional with the compressive strength of concrete but in lightweight the magnitude of cracking load decrease by 7 % compared with traditional weight concrete, despite The lightweight concrete mostly is lighter in weight than the

normal weight concrete by the percentage of 25 %, the torque failure only decrease by 5.5 % and torsional capacity percentage of decreasing has a maximum ceiling of 10%. It has been shown that an improvement in the reinforcement ratio including the addition of steel fiber enhanced the torsional strength, ductility and cracking resistance of the concrete. Poh Yap [6], studied the oil palm shell as an aggregate to produce lightweight concrete beams with steel fiber and subjected to torsion. That study used various volume fractions (0–1%) of steel fiber, which concluded to the incorporation of steel fiber significantly boosted the mechanical properties of the oil palm shell fiber reinforced concrete mixes, including the compressive and tensile strengths, and reduced the brittleness of the oil palm shell steel fiber reinforced concrete. For the post-cracking torsional behavior, the ultimate torque of the oil palm shell steel fiber reinforced concrete beams was noticed to be 30–60% higher than that of the oil palm shell concrete beam. Beyond the ultimate torque, an increasing of 260% of the torsional toughness was achieved in the 1% steel fiber volume. Poh Yap [7], also studied the effect of fiber aspect ratio in normal and lightweight concrete beams under torsion. Using 3 aspect fiber ratios 55, 65 and 80 for the same volume fraction 0.5%. It can be deduced that the inclusion of steel fiber actually reduced the crack widths of both the normal weight steel fiber concrete and OPSFRC specimens by about 30–43% and 42–60%, respectively, with multiple fine cracks propagated along the primary crack. The tension stiffness mechanism gave the ability to the concrete to resist a higher torsion loading and twist before the failure of the beam. Anto George [8], investigated 8 mixes of lightweight concrete using coconuts shell as an aggregate to produce lightweight concrete beams. This study used the addition of four steel fiber volume fraction ratios to lightweight concrete beams. It is concluded that

Coconut shell can be grouped under lightweight aggregate because 28-days air-dry densities of coconut shell aggregate concrete are less than 2000 kg/m³. The Density of coconut shell is in the between 550 and 650 kg/m³. Coconut shell concrete produces beams of higher torsional capacity than normal weight concrete. 0.75% steel fibers caused an increment of torsional capacity by 155% in NWC and 51% in coconuts shell concrete.

2. Research significance

The design requirements for the torsional design of lightweight concrete (LWC) did not provided in design codes such as ACI [9], BS [10] and CSA [11]. LWC has gained high attention, because of its space and cost efficiency. The use of LWC decrease the dead load of the structural element and it permits the design small cross section for members and foundations. This investigation presents numerical study of the effect of fiber on the torsional behavior of lightweight concrete beams to develop the comprehension of the performance of lightweight concrete under pure torsion, which, ultimately, provide the assistance for the torsional design of lightweight concrete. The current research provides a rational approach equation that could predict the magnitude of torsional capacity of light-weight concrete beams with or without steel fibers volume fraction.

3. Calibration and validation

The basic finite element model was calibrated based on the tested specimen by Domat [12]. A 350 mm deep concrete beam was designed with a span of 1000 mm. the length of the beam is 1000 mm and with dimensions of 150 mm ×350 mm reinforced with 2φ10 mm for the longitudinal reinforcement rebars located at top, middle and bottom of beam cross section. The transverse reinforcement of the beam is φ8 mm steel stirrups spaced equally at 150 mm. Specimen geometry, steel detailing, and setup is illustrated in Fig 1.

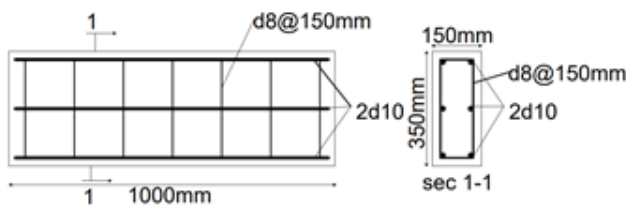

Fig 1 geometry and reinforcement details of verification model by Domat [12].

Equation (1) is used to represent the uniaxial stress-strain relationship for lightweight concrete using Madrid parabola recognized by Comities Euro-International du B'eton (CEB), Kmiecik, p., [19] where:

$$F_c = \epsilon_c * E_c [1 - (\epsilon_c / 2 \epsilon_{c1})] \tag{1}$$

Where: ϵ_{c1} is the strain at peak stress,

$$\epsilon_{c1} = 0.0014 * [2 - \text{EXP}(-0.024 * f_{cm}) - \text{EXP}(-0.14 * f_{cm})] \tag{2}$$

Where f_{cm} is average compressive strength of concrete, ϵ_c is the strain at any point, F_c is stress at strain equal ϵ_c .

The beam was simulated with ANSYS 21 [13], which presents a set of various solid nonlinear capabilities for analysis. Solid 65 can be used to simulate concrete with or without reinforcement rebar and has the ability for modeling cracking in tension, crushing in compression, plastic deformation and creep behavior. Link 180 can be utilized for reinforcement which contains plasticity, stress stiffness, creep, strain capabilities and large deflection. Solid 45, which has plasticity, creep, stress stiffening, large deflection, and large strain capabilities used for loading moment arms and supports plates. The mesh size in the model is 50 mm to confirm the model accuracy as illustrated in Fig 2. The loading of the ANSYS model and torsional moment diagram is shown in Fig 3 and Fig 4 respectively.

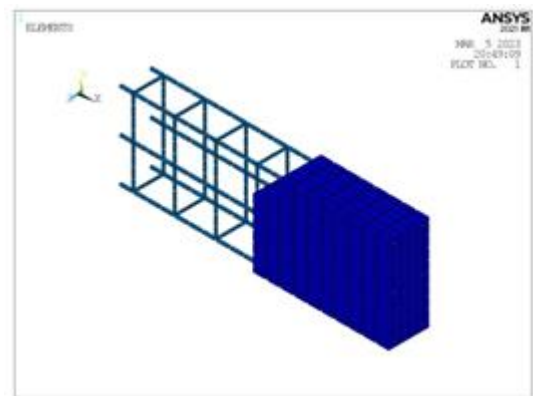

Fig 2 Verification ANSYS model concrete and reinforcement meshing.

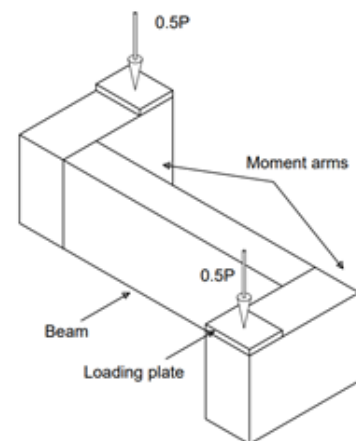

Fig 3 Verification ANSYS model loading.



Fig 4 Torsional moment of Verification ANSYS model.

The accuracy and the convergence of the results principally rely on the mesh size and the continuity of mesh lines. The bilinear elastic-plastic stress-strain for steel reinforcement to be used with Link180 element is consist of two series of data. Modulus of elasticity of 200000 N/mm² and Poisson's ratio of 0.3 is utilized to produce a linear isotropic model, which is for the elastic rang. In order to provide

perfect bond between concrete and steel material, both of them share the same points to take the advantage of merge nodes option to collect disconnected entities that have the same location into a single one.

The model were carefully created by obtaining the optimum magnitude of concrete’s open and close crack coefficients, which make a major impact on the solution convergence after cracks distribution. In order to avoid solution divergence or sudden failure, the number of the load sub-steps increases. Fig 5 illustrates the Torque- Angle of twist curves of Domat[12] beam for the experimental, ANSYS result, and current verification. Fig 6 shows the cracks at failure in the verified concrete beam. It is demonstrated that the maximum torque based on the current investigation finite element analysis is slightly lower than the maximum torque reached in the test by 7 % but slightly higher than the maximum torque reached in Domat ANSYS model result by 1%.The numerical results presented good agreement with the experimental results in all sides of comparison. The stresses of the model is shown in Fig 7. It can be deduced from the previous comparison that the current validation finite element model is reliable; this model will be applied to investigate the parameters that govern and influence the behavior of light-weight concrete beams.

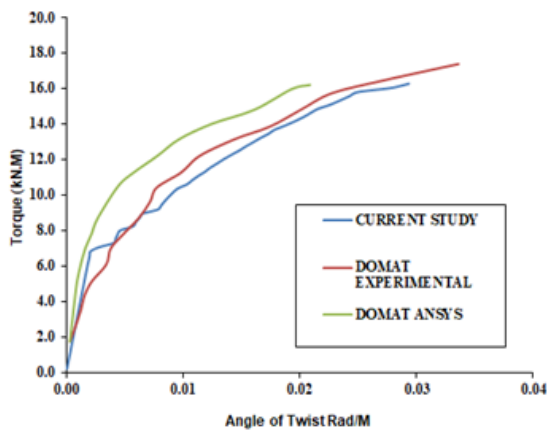

Fig 5 comparison between current study verification model, experimental and analytical model by Domat [12].

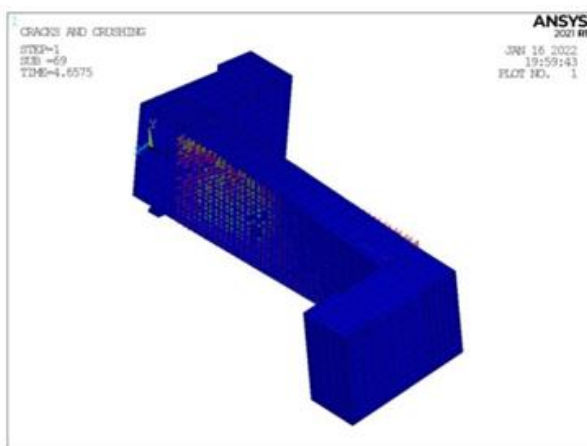

Fig 6 Verification ANSYS model cracks at failure.

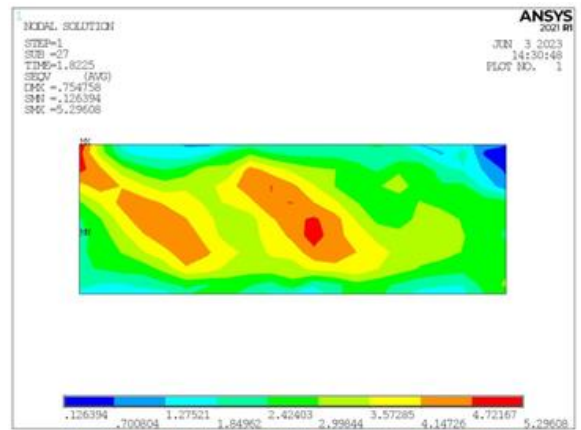

Fig 7 Verification ANSYS model stresses.

Table 1 comparison between results of current study and results of Domat [12] study .

Domat study	ANSYS results In Domat study	Experimental results In Domat study	ANSYS results for verification model in this study
Max KN load	92.5	100	93.15
Ultimate torque KN.m	16.2	17.5	16.3

4. Numerical study

Implementing experimental investigations to study pure torsion problem with many variables is tough matter on concrete beams generally and lightweight concrete beams specifically. Further, experimental specimens are quite limited in number because of the high budget of tests. Therefore, finite-element analysis is a more economic method which helps have optimal specimens models as a replacement of experiments. So many investigators have so far headed to study concrete elements numerically.

4.1 Effect of compressive strength

The control lightweight concrete beam with compressive strength F_{cu} equal 28 MPa, the ultimate torque is 15.83 KN.m. As shown in Fig 8, increasing of lightweight concrete compressive strength, as expected, reduces significantly the beam angle of twist. At 75 % of ultimate torque, the angle of twist of 37 MPa compressive strength lightweight concrete beams is reduced by 31.66 % compared to 19 MPa compressive strength lightweight concrete beams. There is a slight enhancement in torque when F_{cu} increases from 35 MPa to 37 MPa, while a significant enhancement at the changing F_{cu} from 19MPa and 28MPa to 37MPa. The torsional capacity of the lightweight concrete beam with F_{cu} equal 37 MPa is about 1.026 times that of F_{cu} equal 35 MPa , about 1.165 times that of F_{cu} equal 28 MPa and about 1.44 times that of F_{cu} equal 19 Mpa. The torsional capacity of the lightweight concrete beam with F_{cu} equal 45 MPa is about 1.5 times that of F_{cu} equal 19 MPa as shown in Fig 5.

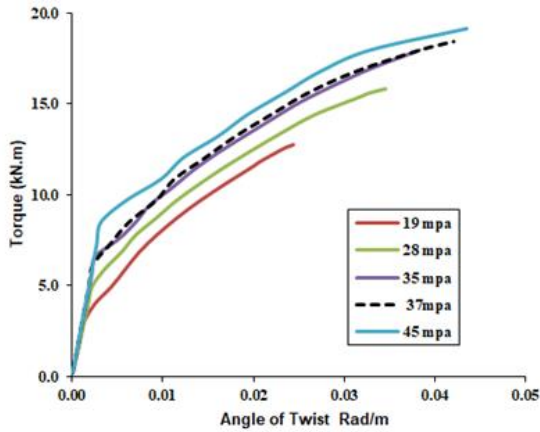

Fig 8 effect of compressive strength on Torque- Twist relation .

4.2 Effect of fiber type

The previous investigations [6],[7],[8] deduced that fibers improve the lightweight concrete mechanical properties. Fiber improves the stiffness of the concrete beams, which decreases the angle of twist. At 75 % of the ultimate torque (which equals 15.83 KN.m), carbon fiber decreases the angle of twist up to 23.99 %, while steel fiber reduces the angle of twist up to 22.14 % compared to control no addition lightweight concrete beam. Glass and polypropylene fiber have a lower effect on lightweight concrete beams, as the angle of twist had reduction up to 11.50 % and 6.08 % respectively. The addition of fiber is influential in enhancing the torsional capacity of the lightweight concrete beams, as the torque improved by 77.64%, 37.31 %, and 76.02% for carbon, glass, and steel respectively. pp is the lowest type of fiber in boasting the torque, which increased up to 26.9 % as illustrated in Fig 9.

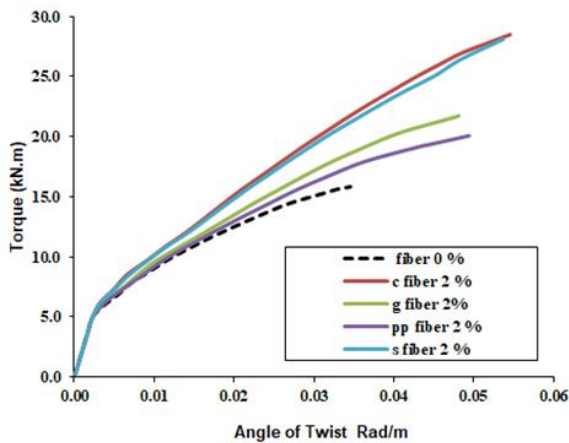

Fig 9 effect of fiber type on Torque- Twist relation

4.3 Effect of fiber volume ratio.

4.3.1 Effect of Steel fiber volume fraction ratio.

Steel fiber is the most common type fiber used to reinforce concrete with modulus of elasticity equals 210 GPa, 7.78specific gravity and 1.7GPa tensile strength [14]. In order to analyze the influence of the fiber fraction volume on the torsional behavior of lightweight concrete beams, four

different volume ratio were investigated by software ANSYS. At 75 % of the ultimate torque (which equal 15.83 KN.m) , 0.5 % steel fiber ratio decrease the angle of twist by 9.30 % compared to control no addition lightweight concrete beam . In addition to 1%, 1.5% and 2% steel fiber ratios achieve reduction in angle of twist 17.98 %, 21.99 % and 21.78 % respectively. When using 28 MPa compressive strength lightweight concrete, the steel fiber ratio highly affected the ultimate torque of the beams. The torque enhanced by 28.28% , 47.76 %,65.58 %and 76.02% when using 0.5% , 1% ,1.5% 2% steel fiber ratios respectively as shown in Fig 10 .

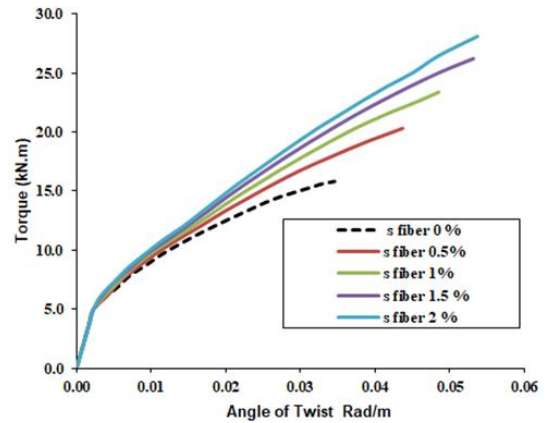

Fig 10 effect of steel fiber ratio on Torque- Twist relation.

4.3.2 Effect of carbon fiber volume fraction ratio.

The Carbon fibers have many different advantages: high stiffness, high strength to weight ratio, and high tensile strength. Common carbon fibers have high tensile strength (ranging from 3000 to 7000 GPa),1.82 specific gravity and high modulus of elasticity (ranging from 200 to 500 GPa) [18]. At 75 % of the ultimate torque (which equal 15.83 KN.m) , 0.5 % carbon fiber ratio decrease the angle of twist by 10.28 % compared to control no addition lightweight concrete beam . In addition to 1%, 1.5% and 2% carbon fiber ratios achieve reduction in angle of twist 19.51 %, 23.37 % and 23.85 % respectively. When using 28 MPa compressive strength lightweight concrete, the carbon fiber ratio highly affected the ultimate torque of the beams. The torque enhanced by 37.31%, 49.17 % ,70.05 % and 77.64% when using 0.5% , 1% ,1.5% 2% carbon fiber ratios respectively as shown in Fig 11.

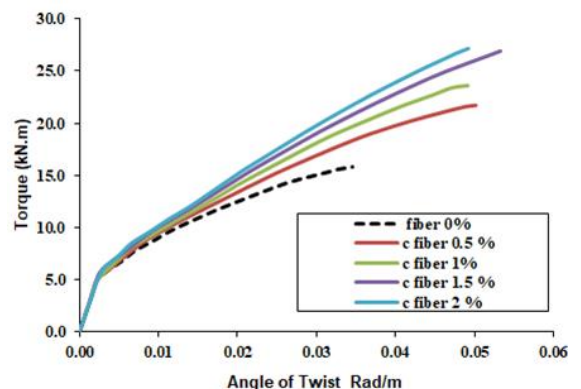

Fig 11 effect of carbon fiber ratio on Torque- Twist relation.

4.3.3 Effect of glass fiber volume fraction ratio.

Glass fiber has practically comparable mechanical properties to other fibers such as polymers and carbon fiber. Although not as rigid as carbon fiber, it is much cheaper and has young modulus equals to 72 GPa, 2.5GPa tensile strength and 2.67 specific gravity. At 75 % of the ultimate torque (which equal 15.83 KN.m) , 0.5 % carbon fiber ratio decrease the angle of twist by 8.27 % compared to control no addition lightweight concrete beam. In addition to 1%, 1.5% and 2% glass fiber ratios achieve reduction in angle of twist 10.53 %, 12.38 % and 14.22 % respectively. When using 28 MPa compressive strength lightweight concrete, the glass fiber ratio highly affected the ultimate torque of the beams. The torque enhanced by 17.91% 25.30%, 32.76 % and 37.31 % when using 0.5%, 1%, 1.5% 2% glass fiber ratios respectively as shown in Fig 12.

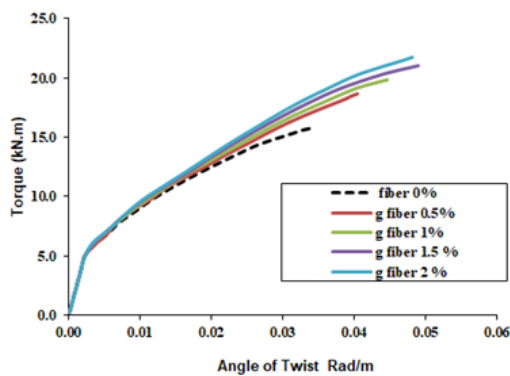

Fig 12 effect of glass fiber ratio on Torque- Twist relation.

4.3.4 Effect of pp fiber volume fraction ratio.

Polypropylene (PP) fibers are a kind of synthetic fibers with valuable features that make them a considerable addition to materials of construction, which have young modulus equals to 38GPa and from (0.3-0.45) GPa tensile strength [15]. At 75 % of the ultimate torque (which equal 15.83 KN.m) , 0.5 % pp fiber ratio decrease the angle of twist by 3.10 % compared to control no addition lightweight concrete beam . In addition to 1%, 1.5% and 2% carbon fiber ratios achieve reduction in angle of twist 7.25 %, 12.08 %and 6.73% respectively. When using 28 MPa compressive strength lightweight concrete, the pp fiber ratio has a moderate effect on the ultimate torque of the beams. Fig 13 presents that the torque enhanced by 11.94 % , 17.84 % , 20.82 % and 26.9 % when using 0.5%, 1%, 1.5% 2% carbon fiber ratios respectively.

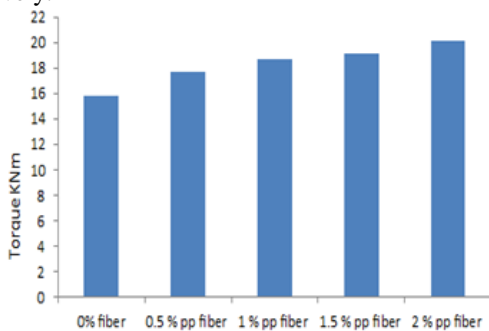

Fig 13 Effect of PP fiber ratio on Torque value.

4.4 Effect of using CFRP bars reinforcement

CFRP bars as reinforcement for concrete has become a promising choice in the latest Years, as it is a new mechanism in order to solve the steel reinforcement corrosion issue. for the same diameter of the longitudinal reinforcement steel bars 10 mm CFRP bars is used instead and get improvement of the torsional capacity of the tested beams for each compressive strength 19 MPa, 28 MPa, 35 MPa and 37 MPa by 3.7 %, 5.91 % , 3.84 % and 3.94 % respectively as presented in Fig 14.

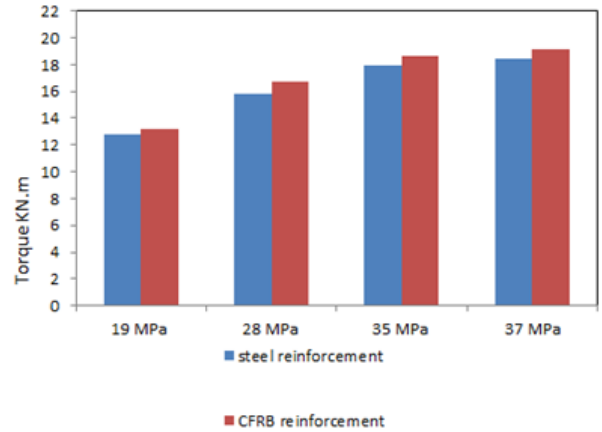

Fig.14. comparison between CFRP bars and steel bars.

4.5 Effect of spacing between the stirrups

The transverse reinforcement provides shear strength to the beam and improves its ductility. as presented in Fig 15 the torque for each compressive strength 19 MPa , 28 MPa , 35 MPa and 37 MPa increased by 5.55% 4.47% 5.12 % and 3.84 % respectively when decreasing spacing from 200 mm to 150 mm. the torque for each compressive strength 19 MPa , 28 MPa , 35 MPa and 37 MPa increased by 5.55% , 8.95% , 3.31% and 3.94% respectively when decreasing spacing from 150 mm to 100 mm.

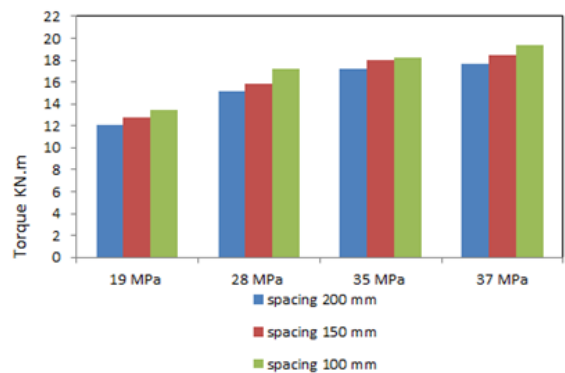

Fig.15.effect of spacing between stirrups

4.6 The effect of stirrups diameter

In this section, the influence of changing the transverse reinforcement ratio on lightweight concrete beam was inspected. As illustrated in Fig 16 when 19 MPa compressive strength used the torque increased by 1.8 % and 3.7% when the diameter increases to 10 mm and 12 mm respectively. For

the same distance between the stirrups When 28 MPa compressive strength used the torque increased by 3 % and 4.47% when the diameter increase to 10 mm and 12 mm respectively. When 35 MPa compressive strength used the torque enhanced by 1.32 % and 6.57% when the diameter increase to 10 mm and 12 mm respectively. When 37 MPa compressive strength used the torque improved by 2.56 % and 6.41% when the diameter increase to 10 mm and 12 mm respectively.

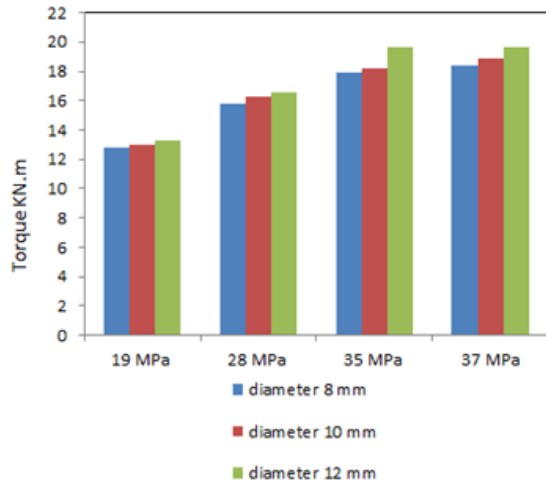

Fig.16. the effect of stirrups diameter on torque of LW C beam.

4.7 Proposed model for lightweight concrete torque.

Most of code provisions are devoted to normal aggregate concrete and are not appropriate for the torsional design of lightweight concrete then; the codes do not take into consideration the influence of fiber addition . Narayanan and Kareem-Palanjian [16] proposed a formula for torsion design of steel fiber reinforced concrete rectangular beams, where the torque is calculated using the equation:

$$T = 0.13x^2y\sqrt{Fcu} + 0.22F \frac{x_0y_0}{x_0+y_0} xy\sqrt{Fcu} + k_2 \frac{x_1y_1}{s} A_s f_{ty} \tag{3}$$

While x and y are the smallest and largest dimensions of the concrete section respectively. F is the fiber factor, which is taken as $\beta (l_f/d_f)$ pf and β is the bond coefficient of steel fiber ,it is related to the shape of fiber and it can be taken 1,0.75 and 0.5 for hooked, crimped, and straight fiber respectively[17] . (l_f/d_f) is the aspect ratio between the length and diameter of the steel fiber, pf is the fiber ratio. x_0 and y_0 is $(5/6)x$ and $(5/6)y$ respectively, while x_1 and y_1 can be calculated by $0.9 x$ and $0.9 y$ respectively . k_2 is the longitudinal reinforcement factor, which is calculated from the equation:

$$k_2 = \left[0.2m + \sqrt{m} \left(\frac{0.45y_1}{x_1} + \frac{s}{x_1+y_1} \right) \right] \tag{4}$$

While m is the ratio between the longitudinal and transversal reinforcement, which is taken as $\rho_l f_{ly}/\rho_t f_{ty}$; ρ_l and ρ_t are the longitudinal and stirrups steel reinforcement ratios; f_{ly} is the yield stress of the longitudinal steel reinforcing bars, f_{ty} is the yield stress of the transversal steel .s is the spacing between the stirrups.

Starting from the earlier equations, and established on the numerical results obtained from the present study and taking into account the experimental results of several researchers; an empirical equation to calculate the torsional capacity of lightweight concrete beams can be presented. This equation estimates the maximum torque of lightweight concrete beams with or with-out steel fiber as function of lightweight concrete compressive strength F_{cu} , beam cross section ,reinforcement details, and the steel fiber ratio derived from equation (5).

$$T = 0.224x^2y\sqrt{Fcu} + 0.67F \frac{x_0y_0}{x_0+y_0} xy\sqrt{Fcu} + k_2 \frac{x_1y_1}{s} A_s f_{ty} \tag{5}$$

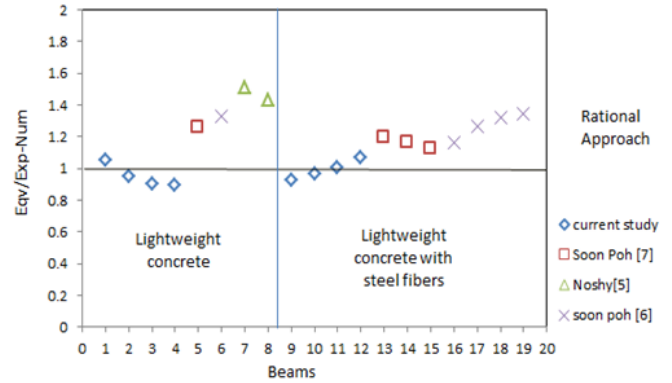

Fig 17 The application of the rational approach on current study and previous studies for lightweight concrete beams with and without steel fibers addition.

The application and comparison of the diverse factors between the current numerical and/or experimental results and the proposed model are presented in table (2). Based on the preceding results obtained using the proposed equation (3), it can be detected that: For lightweight compressive strength from 19 MPa,28 MPa,35 MPa, and 37 MPa , the equation achieves reasonable torsional capacity, as the ratio between Equivalent Proposed model results and numerical results varies from 0.9 to 1.05. Besides the ratio between the Equivalent Proposed model results and numerical results for the torsional capacity of the lightweight concrete beam with steel fiber addition varies from 0.93 to 1.06, which could be in the acceptable range. Fig 17 shows the application of the proposed model on the pervious torsional behavior of lightweight concrete beams investigations. The application of the proposed equation on Soon Poh Yap[7] [6] beams gives agreeable results, while the application on Noshy [5] beams shows a low quality and it can be deduced that more research in this topic is needed.

The equation (4) that calculates the torsional moment of concrete term according to ACI[9] is

$$T_u = \phi 0.33\lambda\sqrt{f'_c} \left(\frac{A_{cp}^2}{P_{cp}} \right) \tag{6}$$

While ϕ = strength reduction factor, λ = modification factor reflecting the reduced mechanical properties of lightweight concrete. A_{cp} and P_{cp} is the section area and perimeter respectively.

Table 2 Comparison between numerical results , proposed model results and ACI equations.

Parameter values			Ultimate torque(KN.m)		Equivalent	ACI equation	Reference
F _{cu} MPa	Fiber %	Aspect ratio	Equivalent Proposed model	Numerical and/ or experimental	Proposed model % /Numerical and or experimental	application /Numerical and or experimental	
19	-	-	13.42	12.75	1.05	0.80	Current study
28	-	-	15.069	15.828	0.95	0.72	
35	-	-	16.17	17.955	0.90	0.68	
37	-	-	16.465	18.427	0.90	0.67	
28	0.5	55	18.825	20.31	0.93	-	Current study
28	1	55	22.55	23.38	0.97	-	
28	1.5	55	26.275	26.23	1.00	-	
28	2	55	30	28.11	1.06	-	
32.8	-	-	6.93	5.5	1.26	0.82	Soon Poh Yap[6]
32.8	0.5	55	8.81	7.36	1.19	-	
32.8	0.5	65	9.14	7.88	1.15	-	
32.8	0.5	80	9.66	8.6	1.12	-	
33.9	-	-	7.02	5.28	1.32	0.87	Soon Poh Yap[5]
33.9	0.25	55	8.127	6.98	1.16	-	
33.9	0.5	55	9.239	7.32	1.26	-	
33.9	0.75	55	10.343	7.85	1.31	-	
33.9	1	55	11.449	8.5	1.34	-	Noshy [4]
26.5	0	0	10.13	6.7	1.51	1.30	
29.5	0	0	12.34	8.6	1.43	1.046	

The equation (5) that calculates the torsional moment of transverse reinforcement according to ACI is

$$T_n = \frac{2A_o A_t f_{yt}}{s} \cot \theta \quad (7)$$

While where A_o shall be determined by analysis except that it shall be permitted to take A_o equal to $0.85A_{oh}$; θ shall not be taken smaller than 30 degrees nor larger than 60 degrees. A_t = area of one leg of a closed stirrup resisting torsion within spacing s , mm². The application of ACI equations shows underestimation of the lightweight concrete torsional capacity.

Conclusions

Established on the non-linear finite element analysis performed in the current research using ANSYS [13] software, the finite element models are efficient at simulating the performance of lightweight concrete beams reinforced with steel and with fiber addition subjected to torsion up to collapse. It can be concluded the following:

1- When the fiber ratio is constant, the increase in compressive strength enhances the torsional capacity of lightweight concrete beams and it can be said that the bonding properties between the concrete and fiber improve as the compressive strength increased.

- 2- The greatest enhancement in the torsional capacity of the lightweight concrete beams was detected in using the addition of carbon fiber with volume ratio 0.2%. The highest torque boasted by 77.64% compared to the no fiber lightweight concrete beam.
- 3- The addition of fiber was the best-examined factor in this investigation. All examined types of fibers improve the mechanical qualities, serviceability, and torsional capacity of lightweight concrete beams.
- 4- Fiber addition succeeded in enhancing the stiffness of lightweight concrete beams, especially carbon fiber decreased the angle of twist up to 23.85%.
- 5- A new rational approach was suggested for the prediction of ultimate torques in lightweight concrete taking into consideration the addition of steel fiber.

REFERENCES

- [1] Hind Hussein Hammad , Zeyad Momtaz Mohamed , and Tmara Rasheed , Using "Attapulgate as a Lightweight Aggregate to Produce Structural and Insulating Concrete" Association of Arab Universities Journal of Engineering Sciences (2019) 26(2): 131–139.
- [2] Sajjad .A .badar, Laith. S. Rasheed , Shakir AA. Salih 2019 , The Structural Characteristics of Lightweight Aggregate Concrete Beams Journal of University of Babylon for Engineering Sciences, Vol. (27), No. (2) pp. 64-73.

- [3] Walid Safwat El- Sayed , Ashraf M. A. Heniegal , Esraa E. Ali , Bassam A. Abd elsalam 2013 PORT SAID ENGINEERING RESEARCH JOURNAL Vol 17 No. 2 September pp: 105 – 116. .
- [4] Samir Mohammed Ahmed, 2014, Behavior of Pre-Stressed Reduced Weight Concrete Beams , Helwan University , Egypt , ELUC.
- [5] Ahmed Noshay Mohammed 2017 “ Torsional Behavior of Light Weight Concrete Beams” the Faculty of Engineering Ain Shams University Egypt Civil Engineering Research Magazine Vol.39 , No. 13 Jan pp. 177-192 .
- [6] Soon Poh Yap, U. Johnson Alengaram *, Mohd Zamin Jumaat, Kuan Ren Khaw 2015 “Torsional behaviour of steel fibre-reinforced oil palm shell concrete beams” Department of Civil Engineering, Faculty of Engineering, University of Malaya, 50603 Kuala Lumpur, Malaysia , Materials and Design vol 87 , pp. 854 -862.
- [7] Soon Poh Yap, U. Johnson Alengaram *, Mohd Zamin Jumaat, Kuan Ren Khaw 2015 “Effect of fibre aspect ratio on the torsional behaviour of steel fibre-reinforced normal weight concrete and lightweight concrete” Department of Civil Engineering, Faculty of Engineering, University of Malaya, 50603 Kuala Lumpur, Malaysia , Engineering Structures vol 101 , pp. 24 -33.
- [8] ANTO GEORGE1 , A. SOFI2, 2018 , “TORSIONAL AND CRACKING BEHAVIOURS OF NORMAL WEIGHT AND COCONUT SHELL LIGHTWEIGHT CONCRETES ” Department of Structural and Geotechnical Engineering, School of Civil Engineering, VIT University, Vellore, India Journal of Engineering Science and Technology Vol. 13, No. 12 (2018) pp. 4104 – 4117.
- [9] ACI Committee 318 (1962), “Building Code Requirements for Reinforced Concrete (ACI 318-56),” ACI Journal Proceedings, American Concrete Institute, Vol. 59, No. 12.
- [10] 10- BS 8110 Standard, 1997. Structural Use of Concrete: Code of Practice for Design and Construction, Part 1, BS 8110. British Standard Institution, UK.
- [11] CSA. Design of concrete structures for buildings. Standard A23.3-94, Canadian Standards Association (CSA), Rexdale, Ont. 1994.
- [12] Wassim Badri Domat 2018 “REPAIR OF R.C. BEAMS SUBJECTED TO TORSION USING CFRP SHEETS ” 2018 Faculty of Engineering at Cairo University Egypt .
- [13] ANSYS 21 Manual Set, ANSYS Inc., South Pointe Technology Drive, FLEXLM License Manager Canonsburg, PA, U.S.A, 2021.
- [14] Syed Safdar Raza ,Liaqat Ali Qureshi, Babar Ali , Ali Raza , Mudasser Muneer Khan , " Effect of different fibers (steel fibers, glass fibers, and carbon fibers) on mechanical properties of reactive powder concrete ", 2020 , fib. International Federation for Structural Concrete , Structural Concrete. 2021;22:334–346.
- [15] Julia Blazya , Rafal Blazyb , "Polypropylene fiber reinforced concrete and its application in creating architectural forms of public spaces" , Case Studies in Construction Materials 14 (2021), P1-1.
- [16] Narayanan, R.; Kareem-Palanjian, A.S. Torsion in beams reinforced with bars and fibers. J. Struct. Eng. 1986, 112, 53–66, doi:10.1061/(ASCE)0733-9445(1986)112:1(53).
- [17] Hyunjin ju , Deuck Hang Lee , Jin-Ha Hwang , Kang Su Kim , Young-Hun oh, 2013 "Fixed-Angle Smeared-Truss Approach with Direct Tension Force Transfer Model for Torsional Behavior of Steel Fiber-Reinforced Concrete Members" Journal of Advanced Concrete Technology 11(9):215-229.
- [18] Sayed Abolfazl Mirdehghan " Fibrous polymeric composites" ,2021, Engineered Polymeric Fibrous Materials pages 1-53.
- [19] Kmiecik, P., (2011), "Modeling of reinforced Concrete Structure and Composites Structure with Concrete Strength Degradation taken into Consideration", Archives of civil and Mechanical engineering.